

COLLECTIVE STATION DISPLAY HUSAR WZS

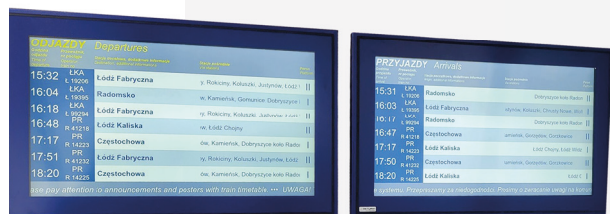

PRODUCT GROUP

HUSAR SCREEN

PRODUCTS IN SERIES

HUSAR WZS, HUSAR WZS E



Scan for more detailed information
about the met standards
and testing of this product

- LCD panels or LED panels optionally (E version)
- 55" matrix – other sizes on request available
- Over 80,000 hours lifetime
- Protection rate IP-65 and IK 09
- Wide operating temperature range: -40 C +60 C
- Built-in brightness level control sensors;
anti-reflective filter
- Sensors for housing opening, glass breakage,
temperature and humidity
- Full compliance with present Polish Railways
standard (PKP PLK S.A. approval)

HUSAR WZS series collective station displays are used to perform all necessary information about the current implementation of the internal timetable at a given railroad station. They are adapted for cooperation with dynamic passenger information systems. Collective station displays are used for installation in the main halls of the station, waiting rooms, at the entrances from halls to tunnels, etc. They provide uninterrupted operation 7 days a week for 24 hours, while maintaining full HD standard.



TECHNICAL DATA OF COLLECTIVE STATION DISPLAY HUSAR WZS

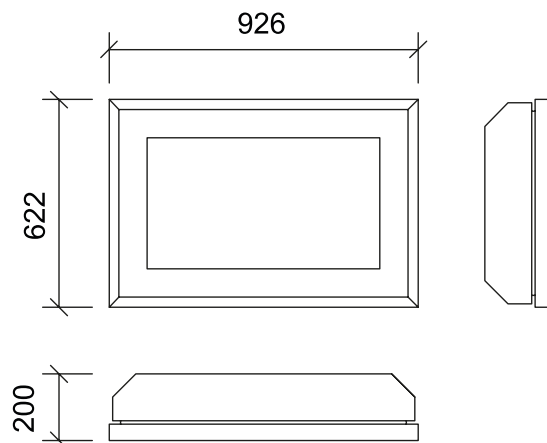

Technical data	
Matrix	LCD -55" (LED matrix optional*)
Active part of a displays	1233,08mm x714,67mm
Resolution	1920x1080
Contrast	5000:1
Luminance	LCD 4000 cd/m ² - LED 5000 cd/m ² (set remotely or automatically on the basis of the external light sensor reading)
Viewing angle	178°/178°
Minimum lifetime	80 000 h
Supply voltage	115 - 230VAC (±10%) 50-60Hz ±1%
Power consumption	350W/750W
Protections	Residual current; overcurrent; overvoltage
Sensors built in	Internal temperature and humidity, case opening, shock, light sensor, glass breakage
Drivers/controllers	backlighting, sensors, heating system, cooling system, for the analysis and execution of CSDIP commands, equipped with a hardware and software watchdog
Protocols	TCP/IP; SNMP V1, V2 i V3; UDP; NTP
Temperature operation range	-40°C do +60°C
Dimensions	1430x891x200 mm
Weight	80 kg
Enclosure	Made of corrosion-resistant material, painted in RAL 5022 (any RAL colour available on request)
IP rate	IP-65 (PN-EN 60529:2003)
IK rate	IK-09 (PN-EN 5012:2001)

*When an optional LED matrix is ordered, the parameters for the matrix itself and power consumption will be different.

This data sheet is commercial in nature. If more detailed technical information is required, the reference document is the technical and operating documentation to be obtained from the manufacturer. In addition, the manufacturer reserves the right to make changes regarding the parameters, specifications and characteristics of the product. The dimensions of optional products, manufactured to order, will have different dimensions than those shown in this sheet. The document of general terms and conditions of supply can be found on the manufacturer's website - www.railway-systems.eu